

Manual for the
70cm-FM/FSK-Transceiver
T7F

Holger Eckardt
DF2FQ
Kirchstockacherstr. 33
D-85662 Hohenbrunn

Technical Data

General

Frequency range:	430 ... 440 MHz
Channel spacing:	12.5 and 25kHz
Receive-transmit delay time:	<30ms
Temperature range:	-5 ... +50° C
Power supply:	7 ... 14V, 60mA RX, max. 2.5A TX
Size:	145 x 75 x 22 mm

Receiver

Sensitivity:	-118dBm for 20dB SINAD (CCITT) @ 1kHz
AF frequency response:	1Hz ... 7,000 Hz (-3dB)
AF total harmonic distortion:	<1%
Intermodulation response:	-54dB (3-tone test)
Adjacent channel response:	<-56dB
Spurious response:	<-60dB (1st image), <51dB (2nd image)

Transmitter

RF power:	1.5W at 7V, 6.5W at 12V
AF frequency response:	1Hz ... 15,000 Hz (-3dB)
AF distortion:	<1%
Spurious transmission:	-66dBc (1st harmonic), <-75dBc else
Spurious transients:	<-40dBc on the adjacent channel

Circuit description

The circuit diagram is spread over four sheets. Figure 1 shows the synthesizer with modulation circuit, figure 2 the receive section, figure 3 the transmitter and figure 4 the control circuit.

Synthesizer

Heart of the synthesizer is the VCO (voltage controlled oscillator) which supplies RX and TX as well. A helix coil guarantees low oscillator noise and low sensitivity against microphony. Separate varicaps are used for tuning and modulation. The VCO works on half the transmission frequency to decouple it from interference by the power amplifier. A doubler follows the VCO, which again is followed by a buffer amplifier. The attenuator between the stages gives some additional decoupling. In the collector circuit of the buffer a notch filter is used to suppress the VCO frequency.

The synthesizer chip MB1504 controls the VCO. The current source of the internal phase detector is much too weak for the fast switching time that is needed, so there is a push-pull amplifier placed on the output of the phase discriminator. It drives the low-impedance loop filter.

The frequency response would be insufficient for packet radio if we would apply the modulation signal only to the VCO. Below the cut-off frequency of the loop filter the deviation would decrease with 6dB per octave. Since the cut-off frequency is 700Hz on 10Hz we wouldn't have hardly any detectable signal of the modulation. Therefore the reference oscillator is modulated as well. The frequency response of this path is complementary to that of the VCO so both paths together give a perfectly flat response.

The reference oscillator is also used to drive the second receiver mixer. Since the reference must be an integer multiple of 25kHz the IF (intermediate frequency) becomes 450kHz instead of the conventional 455kHz. This has to be considered at the crystal filter.

Receiver

Two helix filters act as pre-selector, one ahead and one behind the low noise amplifier T6. The dual-gate FET (field effect transistor) T5 acts as mixer. To obtain a good intermodulation response both stages are driven with a relatively high supply current. Printed inductors match the high impedance gates of the FET. The drain provides the IF signal. Due to the strong requirements for a flat group delay a trimmer is used to optimize the matching of the crystal filter. The filter is followed by a buffer amplifier and then by the IF circuit MC3371. Beside the 2nd mixer this IC contains a limiting amplifier, the demodulator, a RSSI (radio signal strength indicator) circuit and an operational amplifier. The latter is used as a 2nd order low-pass filter to suppress IF spurious on the output signal. The ceramic filter for the 2nd IF is internally compensated for flat group delay response.

The RSSI output provides a current which is proportional to the logarithm of the RF (radio frequency) input voltage. With a buffer amplifier this signal is good to drive a S-meter. It is also used to generate a fast DCD (data carrier detect) signal which is advantageous in particular when operating over multimode digipeaters. Within the dynamic range of the RSSI the potentiometer R53 determines the trigger threshold.

Transmitter

The driver T7 boosts the VCO signal up to 30mW. This is sufficient to drive the PA (power amplifier) module which at 12V supply voltage delivers an output power of 7W. Behind the low pass filter and the pin diode switch a power of 6W or more is available. T8 and T14 generates a linear ramp with a time constant of 5ms. The slow ramping of the PA avoids spurious signals in the adjacent channels. A 5V regulator supplies all stages of the transceiver except driver and PA module. These get the unregulated supply voltage directly.

Control circuit

A micro controller IC is used to control the whole transceiver. It polls the PTT (push to talk) line, programs the synthesizer chip, switches receiver and transmitter path in a well defined time scheme and checks the channel select ports. The required software is stored in the EEPROM within the chip.

Construction

The PCB (printed circuit board) artwork for the transceiver is shown in figure 5. It fits on an area of 144 x 72mm. You can find a part list at the end of this text. Those components which are marked with n.p. in the schematics must not be placed on the board. Values of the capacitors are partly printed in exponential expression, 102 e.g. means 1nF, 473 means 47nF. Basically it is the same as with resistors only instead of colors numbers are used.

It is recommended to start the construction by fitting the low-profile parts (resistors, RF-transistors, etc.), then the capacitors and AF-transistors and finally the larger parts such as crystals and filters. No sockets must be used for the ICs except for IC1. This one however should be placed on a socket as it makes software update much easier. The flat RF transistors have one long terminal, for the bipolar types it is the collector for the FET it is the drain. The type numbers always look away from the PCB. The heat sink of T8 looks to the border of the PCB. D2 (BB405) normally does not have any printed type number on it, it can be recognized by the black body with a white ring. The resonator Q2 already includes the two feed back capacitors. It has a bubble-shaped blue body with three terminals.

Three inductors have to be wound manually. They are marked with 3T3D in the schematics. This means 3 turns, 3mm diameter. Silver plated copper wire of 0.4mm diameter should be used. The terminals of L5 and L11 are stretched to the distance of the through-holes. L12 is wound as tight as

possible . All other fixed inductors look like thick resistors, they are coded by colors. L14 (3.3uH, orange orange gold) and L2-4 (0.33uH, orange orange silver) look very similar, so do L16 (0.1uH, brown black silver) and L18 (1uH, brown black gold).

The only component which is soldered from the rear side of the board is the power module. It is mounted in such a way that the heat sink looks away from the PCB. The distance between the flange and the PCB should be 4mm. This is ensured by two 4mm-spacers. The construction step by step:

Preparing the housing:

- Insert the BNC in the wall connector without washer and tighten the nut.
- Insert the feed-through capacitor from outside the wall and solder from inside. Bend the inner terminal so that it later fits into the hole on the PCB.
- Stick the two side walls of the housing together with the lower cover and solder the edges of the walls from inside.

Preparing the PCB (considered that all components are fitted):

- Solder the four spacers concentric on the pads of the PCB, the 5mm parts on the middle pads, the 4mm ones below the PA module.
- Solder a 3cm piece of wire to the antenna pad for the BNC connector.

Assembly:

- Slip the PCB into the housing frame, connector pins first. Fit frame and PCB onto the lower cover. Adjust the PCB so that the flange of the PA module flushes with the cover.
- Solder all 13 pads of the PCB to the side walls.
- Solder middle pin of BNC connector and feed-through capacitor.
- Fit the aluminum plate onto the lower cover, insert the four screws from outside into the holes and tighten the nuts from the PCB side.
- Stick the upper cover onto the frame.

For usual packet radio operation with not more 30% transmitter duty cycle a 2.5mm aluminum plate is absolutely sufficient as heat sink. Should the transceiver be designed for heavy duty use, e.g. at a digipeater, a heat sink with less than 5K/W is necessary. On the PCB is space for a strong diode (D6) in series with the power connector to prevent damage from the transceiver by applying wrong polarity. Unfortunately the holes are too small for it's legs. So either you drill them up or you can simply mount the diode outside the housing as well.

Setting up the device

The transceiver has 9 adjustment points, anyway the adjustment is simple. The following test equipment is required:

- Digital multimeter,
- Frequency counter capable to measure at least 30MHz with a sensitivity of 20mV,
- Oscilloscope,
- AF generator for sinus and square wave signals,
- A stable source for a 70cm Signal with an adjustable level between -60 and -90dBm (in case you don't have access to a signal generator a portable transceiver with 0.5 W RF power in 30m distance will do).
- A receiver for the 70cm band with good demodulation capabilities (e.g. a scanner receiver with FM-wide mode or a 9k6-capable radio).

- A non-metallic screwdriver for tuning cores and trimmers

Start by connecting the 12V power supply voltage to the board. The current consumption should be about 60mA. After two minutes warming up connect the frequency counter to Pin 2 of IC3 (MC3371). This is the buffered output of the reference oscillator. The voltage at this point is below 100mV_{ss}. Adjust the frequency with R4 exactly to 20.950 MHz. Please keep in mind that every Hz offset produces 20 times the offset on the final frequency. This has also to be considered at the accuracy of the counter. Due to the big coupling capacitors this adjustment reacts relatively slow.

Now enter a receive frequency of 430.000 MHz. In the next chapter it is explained how to enter frequencies in general, for the first you can just switch to channel 0 by leaving all pins of X1 open. Turn L1 clockwise until the voltage at test pad TP1 is 0.8V.

Enter a receive frequency of 435MHz by connecting pin 1 with pin 2 and pin 5 with pin 6 of X1 (this settings of course works only if the PIC is in its original state and no other frequencies have been programmed into the memory). Set the RF-generator to the same frequency and connect a digital voltmeter to the RSSI terminal (pin 10 of X2). The DCD trimmer R54 should be in 12 o'clock position because the RSSI voltage depends a little on the setting of R54. Without input signal the RSSI voltage should be between 0.4 and 0.8 V. Depending on the RF signal the voltage increases. Turn the cores of L6 and L7 and C70 recursively until the RSSI value reaches a maximum. If voltage reaches 3.5V decrease the RF input level to continue the procedure.

The next step is to modulate the generator with a 1kHz sinewave signal of 3kHz deviation. Connect the oscilloscope to the AF output terminal (pin 8 of X2). Turn the core of L9 so that the amplitude of the output signal reaches a maximum and minimize the distortion with C70. An THD value of below 1% should be reached. You can estimate the distortion very well if you have a dual trace oscilloscope where you apply the original signal to the second channel. The receive path is now ready to use.

Before tuning the transmitter make sure that the heat sink is mounted properly and the PCB is soldered firmly in the housing. Reduce the supply voltage to 7.5 volts and connect an AF generator to the modulation input terminal (pin 6 of X2). The generator should be set to an squarewave output of 400mV_{ss} at a frequency of 100Hz. Plug a dummy load or a watt meter to the BNC connector and then put the PTT terminal (pin 4 of X2) to ground. The output power should be about 1.5 W. Check the modulation with a separate receiver tuned to the transmit frequency. An oscilloscope connected to the output of the receiver most likely will show a heavily distorted squarewave signal at first. Turn R41 clockwise until the roof of the squarewave has a perfectly flat shape.

At last set the supply voltage back to 12V and check the output power. It should be 6W or more.

User interface

The transceiver has a 10 pin (X2) and a 14 pin (X1) connector. Table 2 shows the pinout. Pin 1 is located in the upper right corner of the connector with view on the pins. There are female plugs available for flat cable. X1 is used for frequency control, X2 for the link to TNC or modem.

X1:	<u>Pin</u>	<u>Signal</u>	<u>Pin</u>	<u>Signal</u>
	1	D0	2	n.c.
	3	D1	4	n.c.
	5	D2	6	n.c.
	7	D3	8	TXD
	9	n.c.	10	RXD
	11	PTT	12	12.5 / 25kHz
	13	GND	14	+5V

X2:	<u>Pin</u>	<u>Signal</u>	<u>Pin</u>	<u>Signal</u>
	1	GND	2	+5V
	3	DCD	4	PTT
	5	GND	6	MODULATION
	7	GND	8	AF-OUTPUT
	9	n.c.	10	RSSI

n.c. = do not connect

Entering frequencies

The current version 1.4 of the control software allows the use of 12.5 and 25kHz channel spacing. Due to technical reasons the switching time between receive and transmit mode is slightly longer at 12.5 kHz operation. Pin 12 of X1 selects the spacing. By default (pin open) 12.5kHz is selected. If the pin is on +5V 25kHz operation is active.

The transceiver covers the whole 70cm Band, for repeater operation you can choose any frequency offset. The device has a memory for 10 pairs of channels for receive and transmit. The channel is selected by D0 to D3 (pins 1,3,5,7 of X1) in BCD code. This can be done with a BCD switch or by jumpers (jumper inserted=1, pin open = 0). The common terminal of the BCD switch must be connected to ground. D0 is the least significant, D3 the most significant bit. The jumpers can be plugged on adjacent pins, e.g. 1 and 2, 3 and 4 etc. Even that n.c. means no connection, the microcontroller sets those pins to ground during normal operation.

In the original configuration the 10 channels are pre-programmed with 430, 431,... to 439 MHz. This is true only if 25kHz spacing is selected.

Programming of the desired frequencies is done through the serial interface. You need a computer with a RS232 interface (e.g. COM1 or COM2 at DOS computers) and any V24-terminal software which is capable to send characters to it. Such a software is part of most operating systems. Depending on the connector type please regard to table 3 for the exact configuration.

<u>Signal</u>	<u>T7F/X1</u>	<u>SUB-D 25</u>	<u>SUB-D 9</u>
RXD	10	3	3
TXD	8	2	2
GND	13	7	5

The interface parameters must be set on the computer to 1200 BPS (bit per second), no parity, two stop bits, no local echo, no protocol (e.g. for DOS: MODE COM1 12 8 1 N). Now a simple string of characters can be entered to allocate a frequency to a particular memory location:

Cntrrrr[RETURN]

C means the upper case C on the keyboard (HEX 43), n is the memory location 0 to 9 you want to program. rrr is the channel number for the receiver and tt that for the transmitter. The channel number has always 3 digits even if the first digit is zero. It can be computed from the following formula:

$$N=(f-430000)/R$$

N is the channel number, f is the desired operation frequency for RX or TX in kHz, and R is the channel spacing (12.5 or 25kHz). The string is not editable, if you make a mistake press enter and start again. To make it clear here two examples spacing:

Memory location 0, receive frequency 438.100 MHz, transmit frequency 430.500 Mhz, 25kHz spacing:

The string is C0020324.

Memory location 8, receive and transmit frequency 434.125 Mhz, 12.5kHz spacing:

The string is C8330330.

All characters you enter are echoed by the T7F, this is a good way to check the physical link between the devices. If you press E (HEX 45) you get a hex dump of the 40 bytes of memory. If you switch on the power of the T7F the version number of the software is sent on the TXD line.

Modem signals

AF input and output is compatible to most of the existing packet radio modems. The level of the output at 3kHz deviation is 1V_{ss}, the modulation input needs 300...400mV_{ss} to get a deviation of 3kHz. Some modems provide a DC level on the modulation signal. In this case you have to insert a 10µF capacitor in the modulation line (plus pole to the modem).

The transceiver provides a fast DCD signal. Most modems generate a DCD signal internally from the data signal. If you operate on a multi mode digipeater it can happen that the internal DCD does not recognize the "other" mode, so you need the external DCD from the transceiver. Adjust the sensitivity with R53. If it is turned fully counter clockwise the function is disabled.

The delay time to key the transmitter is below 30ms so TXD 3 should be OK for packet radio operation. However some modems takes a certain amount of time by itself for switching so the TX delay can be considerably longer occasionally.

Voice operation and what you can do else

With little additional effort the transceiver also can be used for voice operation. A full description and an extension PCB is available on request from the author. Of course the radio can be used for 1200 BPS packet radio as well, no modification is required. If you want to operate with 19200 BPS you need wider IF filters. FI1 must be replaced by a 21U30A, for FI2 a CFUS450BY is required, C78 should have 330pF instead of 470pF.

Postscript

The published design may be used by everybody for private purposes. Each commercial usage, also from parts of the design requires a permission from the author. The author rejects any liabilities for damages which result from construction or use of the device.

Appropriate construction considered the design is compliant to all requirements of the new European standard for amateur radio equipment ETS 300-684 as well as to the EMC standard EN 55022. However the device is not certified by any administrative body.

For questions and further information the author is available in packet radio or by e-mail under df2fq@amsat.org.

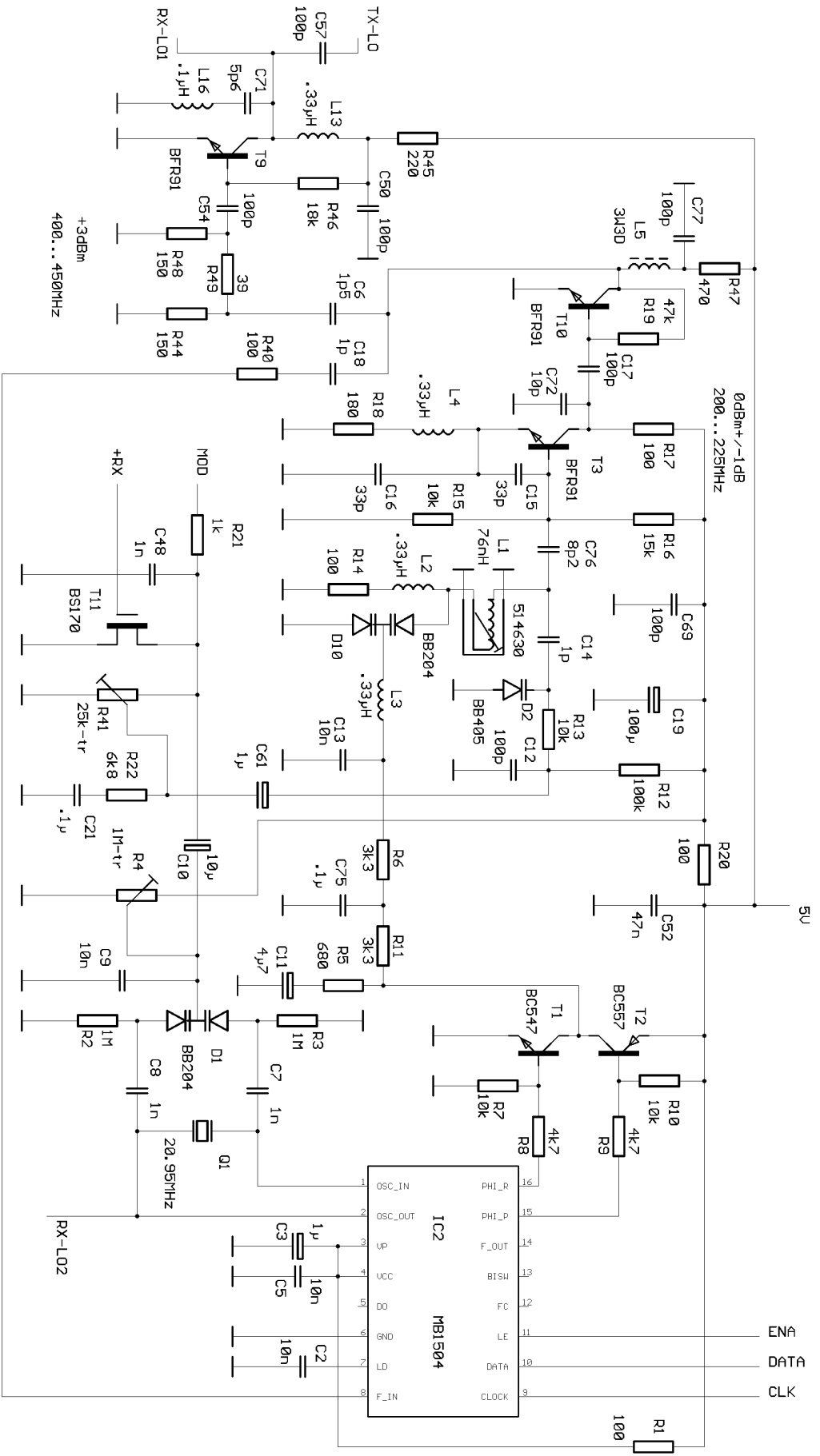

DF2FQ	
TITLE:	T7E
Sheet Title	Synthesizer
Date: 14.10.1999 21:48:22	Sheet: 1/4
REV:	1.3

Fig. 1

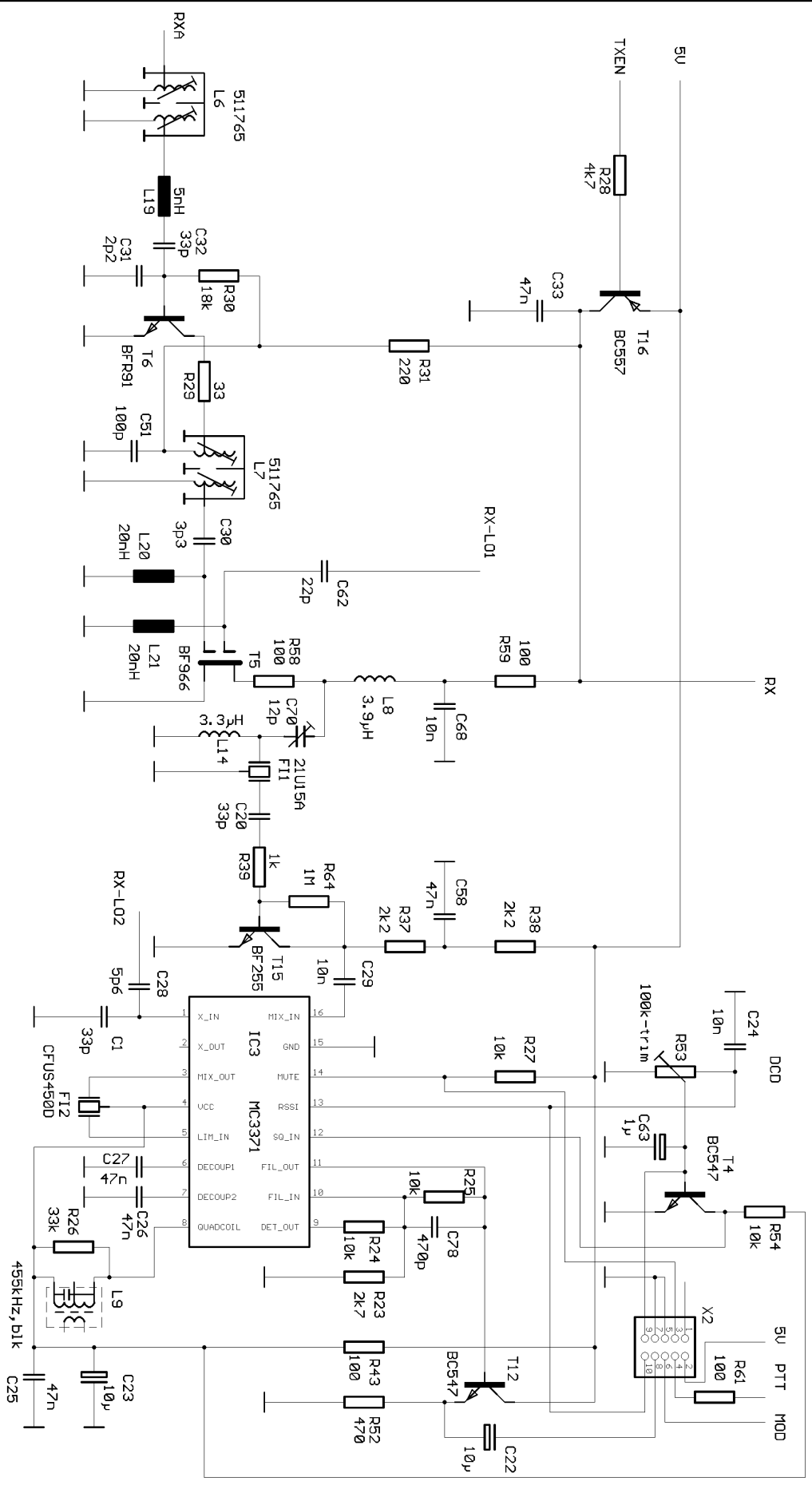

DF2F0	
TITLE:	T7E
Sheet Title	RECEIVER
Date: 09.01.2000 10:52:28	Sheet: 2/4
REV:	1.3

Fig. 2

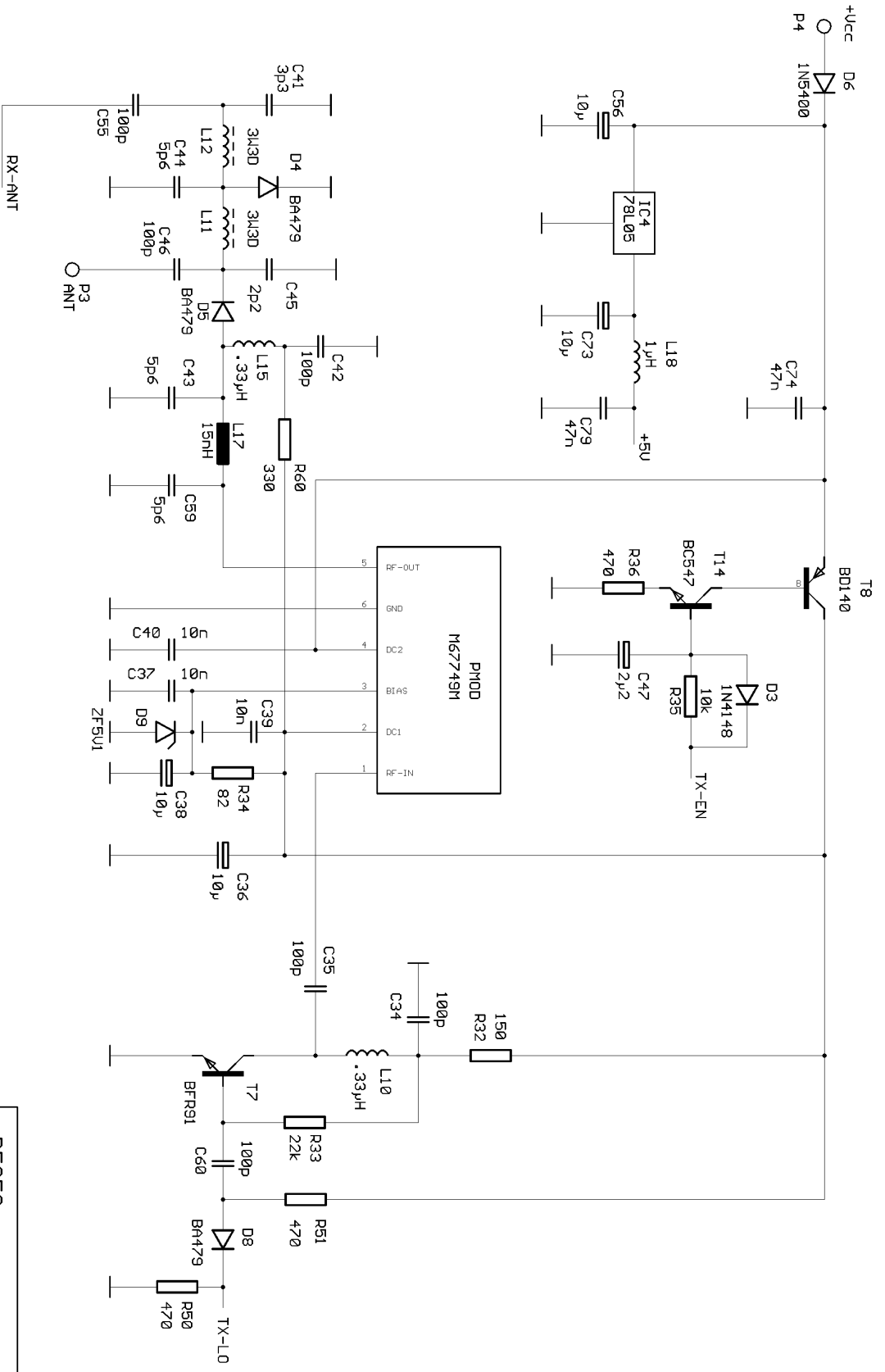

DF2F0	
TITLE:	T7E
Sheet Title	TRANSMITTER
Date: 14.10.1999 21:48:22	Sheet: 3/4
REV:	1.3

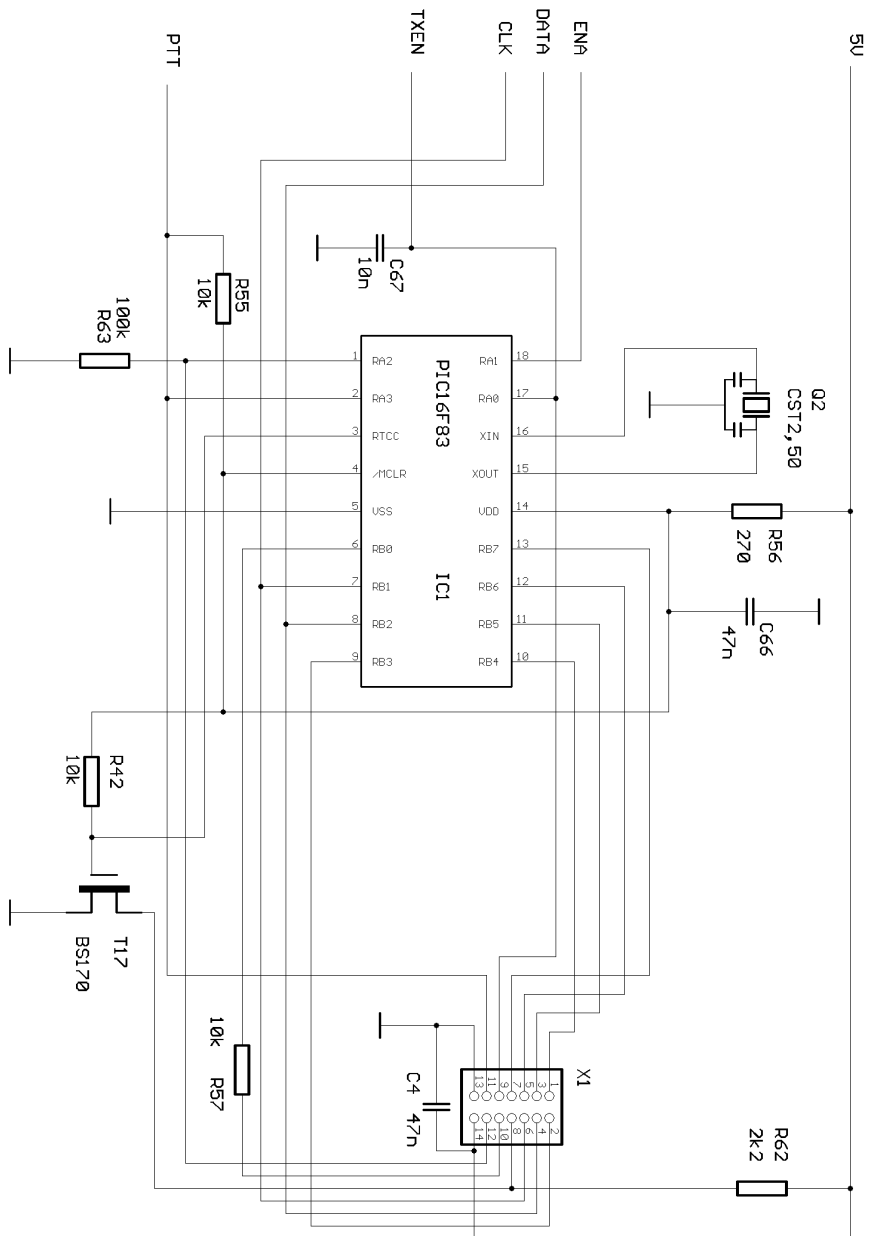

DF2F0	
TITLE: TZE	
Sheet Title	CONTROL UNIT
Date: 14.10.1999 21:48:22	Sheet: 4/4
REV: 1.3	

Fig. 4

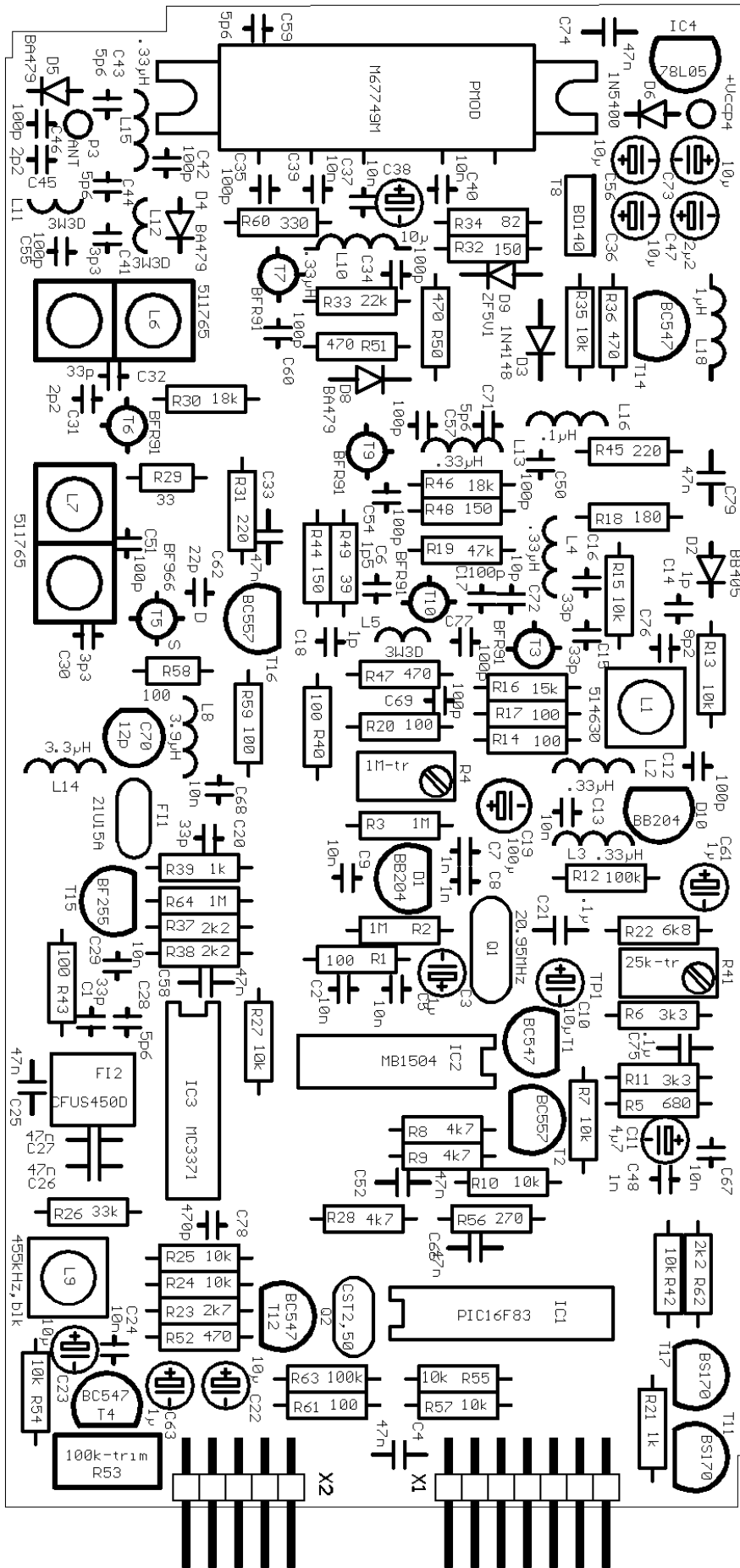

T7F, PCB
DF2FQ, 10.7.99

Fig. 5

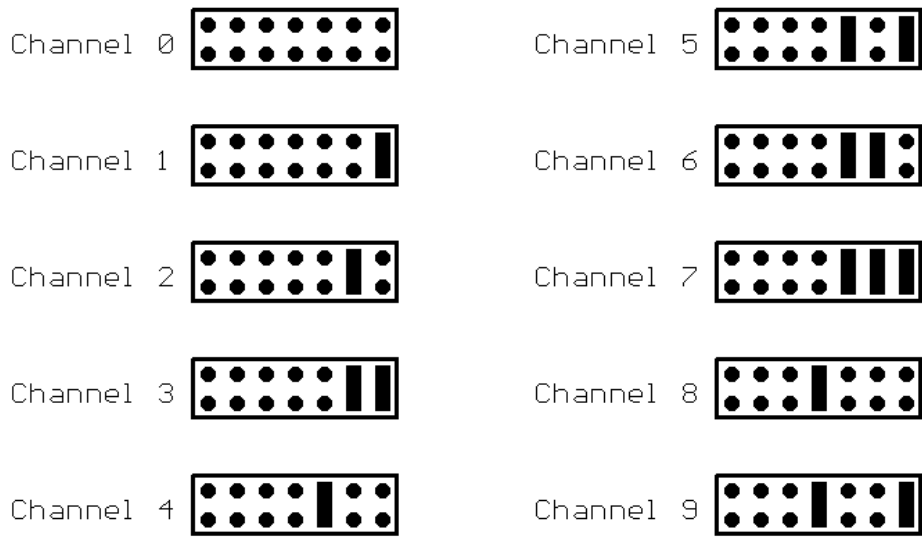

Fig. 6, Jumper position (X1)

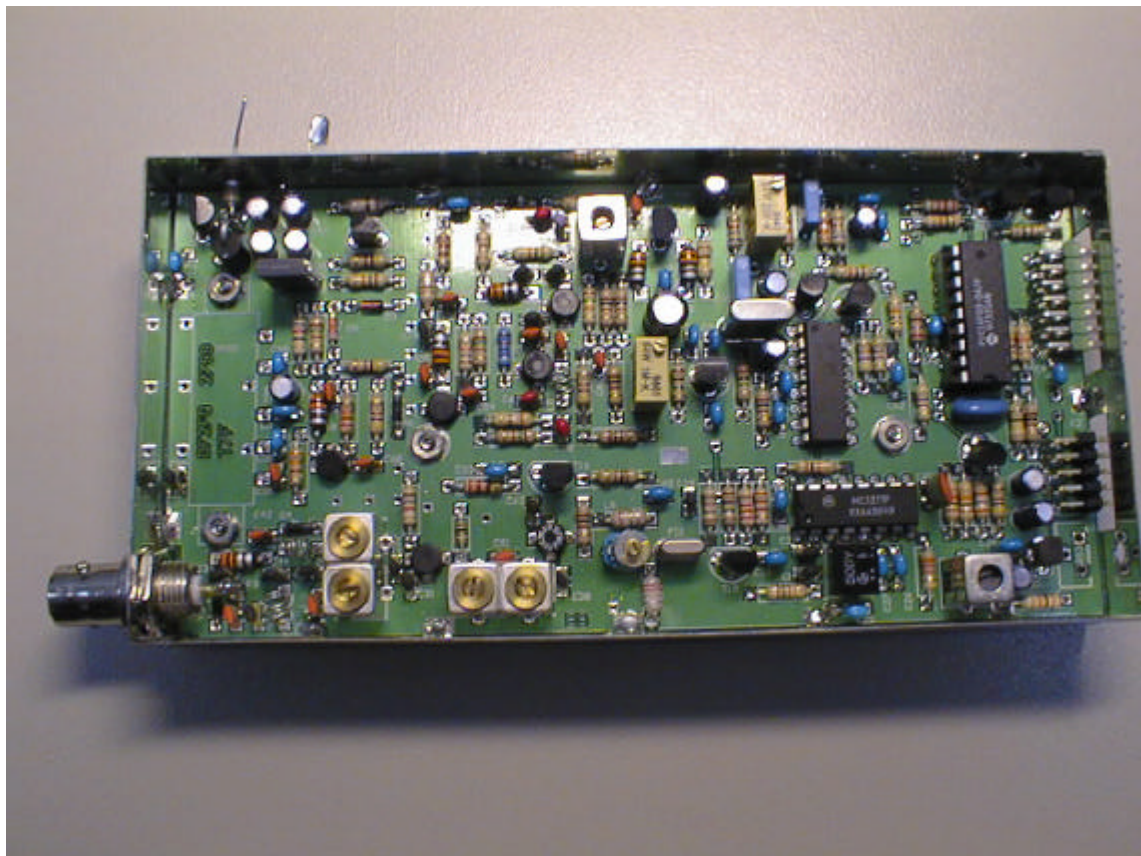

Fig. 7, A picture of the assembled unit

Partlist

C1	33p	C69	100p	R19	47k
C2	10n	C70	12p-trim	R20	100
C3	1μF	C71	5p6	R21	1k
C4	47n	C72	10p	R22	6k8
C5	10n	C73	10μ	R23	2k7
C6	1p5	C74	47n	R24	10k
C7	1n	C75	.1μF	R25	10k
C8	1n	C76	8p2	R26	33k
C9	10n	C77	100p	R27	10k
C10	10μF	C78	470p	R28	4k7
C11	4u7	C79	47n	R29	33
C12	100p	D1	BB204	R30	18k
C13	10n	D2	BB405	R31	220
C14	1p	D3	1N4148	R32	150
C15	33p	D4	BA479	R33	22k
C16	33p	D5	BA479	R34	82
C17	100p	D6	1N5400 or SB320	R35	10k
C18	1p	D8	BA479	R36	470
C19	100μF	D9	BZX55-5V1	R37	2k2
C20	33p	D10	BB204	R38	2k2
C21	.1μF	FI1	21U15A	R39	1k
C22	10μF	FI2	CFUS450DY	R40	100
C23	10μF	IC1	PIC16F83	R41	25k-trim
C24	10n	IC2	MB1504	R42	10k
C25	47n	IC3	MC3371	R43	100
C26	47n	IC4	78L05	R44	150
C27	47n	L1	514630	R45	220
C28	5p6	L2	.33μH	R46	18k
C29	10n	L3	.33μH	R47	470
C30	3p3	L4	.33μH	R48	150
C31	2p2	L5	3W3D	R49	39
C32	33p	L6	511765	R50	470
C33	47n	L7	511765	R51	470
C34	100p	L8	3.9μH	R52	470
C35	100p	L9	455kHz,blk	R53	100k-trim
C36	10μF	L10	.33μH	R54	10k
C37	10n	L11	3W3D	R55	10k
C38	10μF	L12	3W3D	R56	270
C39	10n	L13	.33μH	R57	10k
C40	10n	L14	3.3μH	R58	100
C41	3p3	L15	.33μH	R59	100
C42	100p	L16	.1μH	R60	330
C43	5p6	L18	1μH	R61	100
C44	5p6	PMOD	M67749M	R62	2k2
C45	2p2	Q1	20.95MHz	R63	100k
C46	100p	Q2	CST2.50	R64	1M
C47	2u2	R1	100	T1	BC547
C48	1n	R2	1M	T2	BC557
C50	100p	R3	1M	T3	BFR91
C51	100p	R4	1M-trim	T4	BC547
C52	47n	R5	680	T5	BF966
C54	100p	R6	3k3	T6	BFR91
C55	100p	R7	10k	T7	BFR91
C56	10μF	R8	4k7	T8	BD140
C57	100p	R9	4k7	T9	BFR91
C58	47n	R10	10k	T10	BFR91
C59	5p6	R11	3k3	T12	BC547
C60	100p	R12	100k	T11	BS170
C61	1μF	R13	10k	T14	BC547
C62	22p	R14	100	T15	BF255
C63	1μF	R15	10k	T16	BC557
C66	47n	R16	15k	T17	BS170
C67	10n	R17	100	X1	2X07/90
C68	10n	R18	180	X2	2X05/90